



Since 1994, DIGITAL LEADER Axis Sensitive Co. Ltd



Industrial Explosion Proof Balance Scales

MODEL : FJG-10,20,40,60,100



제품 규격 [UNIT : mm]

Product Specification

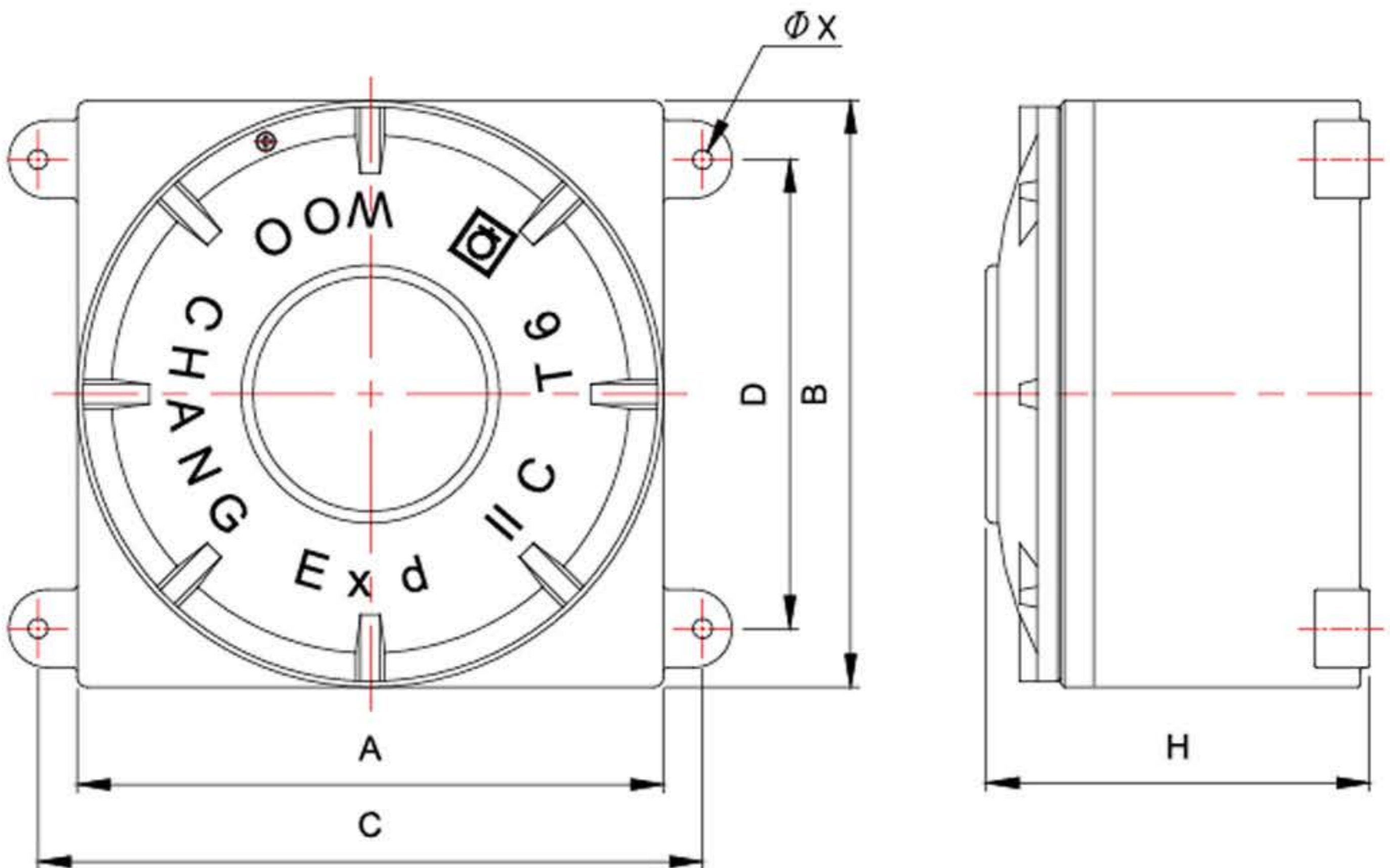

Data

* 방폭형 내압 정션 박스(IIC형)* / *방폭 등급 : Ex d IIC T6 IP65*								
모 델	박스규격	Max. T/B	Dimension(mm)					
		(20A)	A	B	C	D	ØX	H
FJG-10	165X178X150	20 P	165	175	200	145	10	150
FJG-20	190X205X180	20 P	190	205	220	170	10	180
FJG-40	300X300X200	40 P	300	300	335	235	10	200
FJG-60	400X500X240	60 P	400	500	460	400	15	240
FJG-100	500X550X260	80 P	500	550	550	440	15	260

Max. Size hubs that can be used

Max HUB Q'TY (PF, NPT, M)					
Hub Type	박스규격	1/2"(16C)	3/4"(22C)	M30	1"(28C)
		M20	M25		M32
Left & Right / Top & Bottom	165X178X150	5/4	4/3	3/2	3/2
	190X205X180	8/5	5/5	4/4	4/4
	300X300X200	10/10	9/9	7/7	7/7
	400X500X240	13/13	11/11	13/11	7/7
	500X550X260	20/20	14/14	17/15	11/11
Max HUB Q'TY (PF, NPT, M)					
1 1/4"(36C)	1 1/2"(42C)	2"(54C)	2 1/2"(70C)	3"(82C)	4"(104C)
M40	M50	M63	M75	M90	M110
1/2	2/1	1/1	1/- 1/1	-/-	-
3/3	2/2	1/1	2/2	1/1	-
4/4	3/3	3/3	-	2/2	-
5/5	3/3	3/3	-	-/-	-
8/8	5/5	5/5	-	-/-	-

Materials Data

Descriptions	Materials
Body	Cast Aluminum Alloy
Cover	Cast Aluminum Alloy

- ▶ 폭발 위험 물질 계량 및 PSM(Process Safety Management) / 화관법 / 화평법 적용 대상 업체에 사용
- ▶ 석유화학, 화학계열, 도료, 잉크, 가스, LPG 등 폭발 위험성이 있는 제품 업체에 사용