



Since 1994, DIGITAL LEADER Axis Sensitive Co. Ltd

Industrial Explosion Proof Air Hoist



MODEL : H2-100SPB



제품 규격 [UNIT : mm]

Product Specification

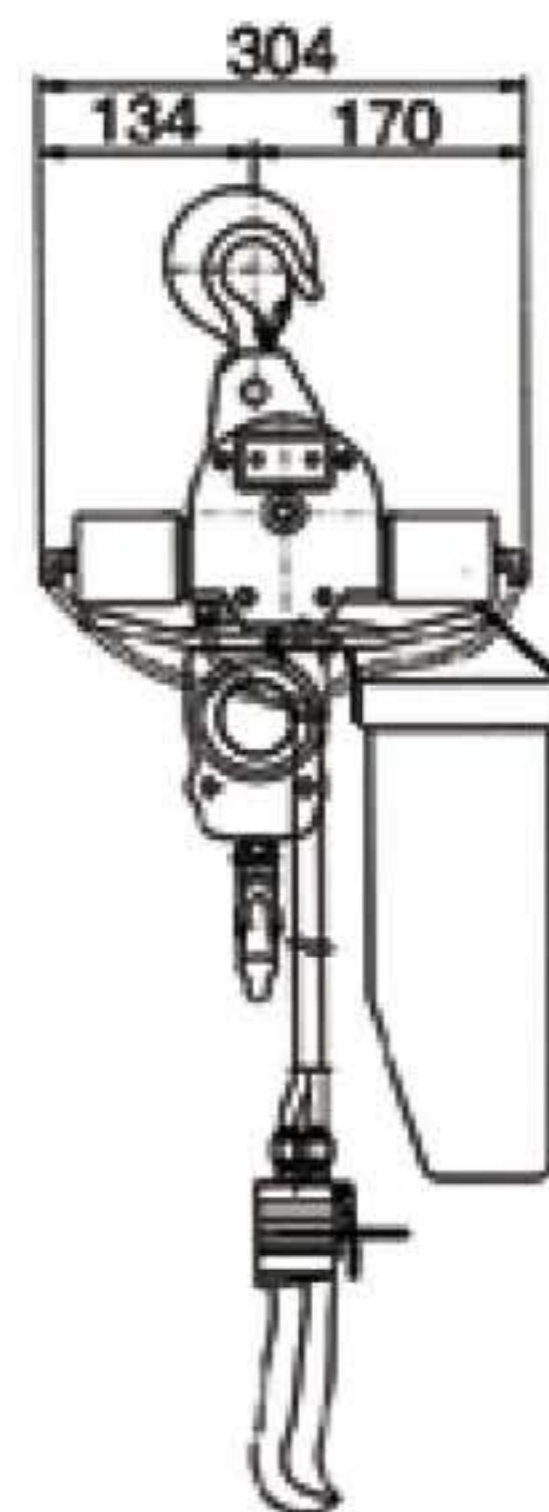
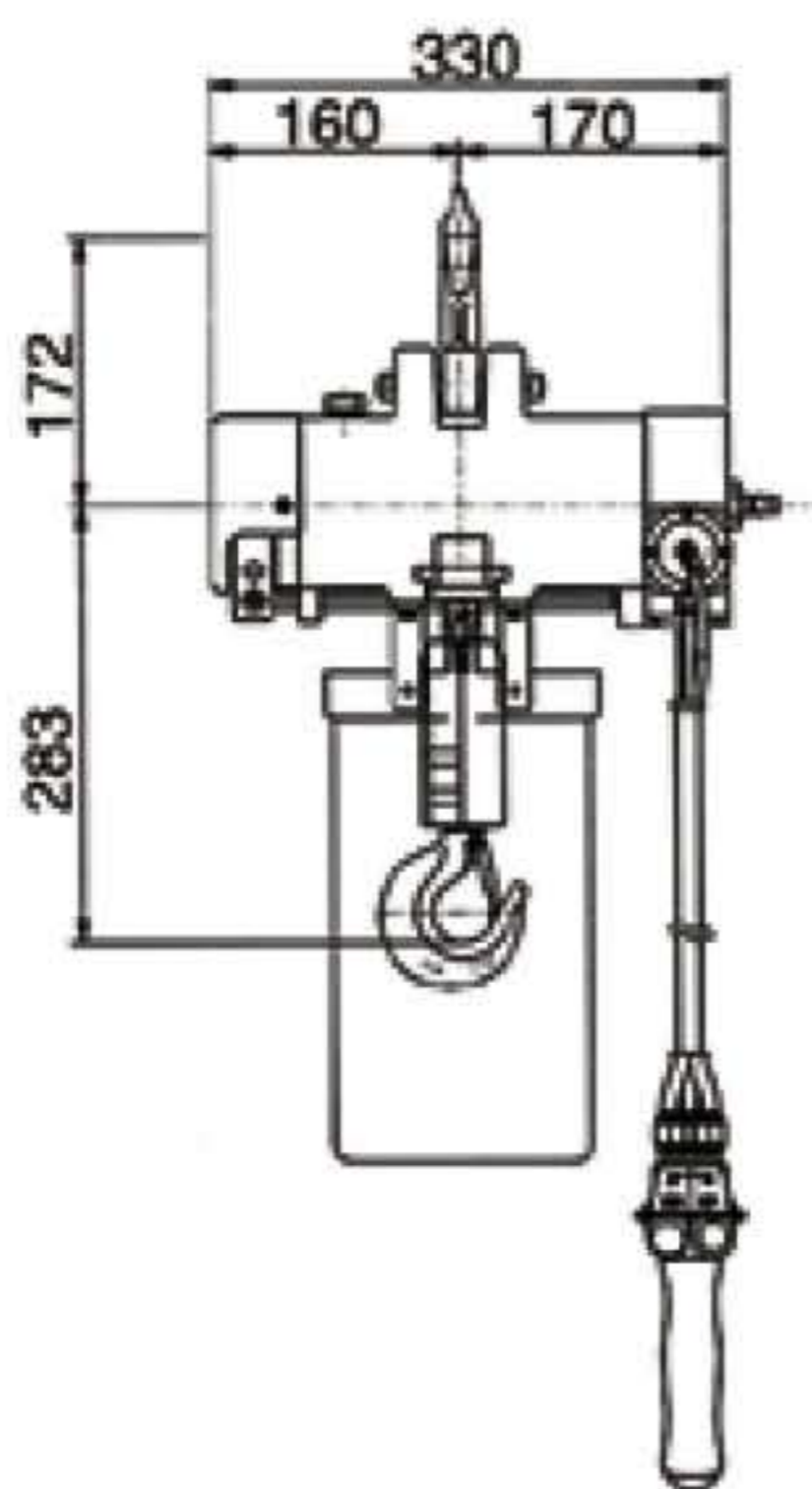

- ▶ H2-100SPB는 상·하 운반용 호이스트
- ▶ PSM 대상 지역 및 인화성, 휘발성, 습기, 분진, 고온 지역 사용
- ▶ 다양한 용량 (250 / 500 / 1,000 / 2,000 kg)의 모델
- ▶ 상·하 이동시 체인의 오버로드 기능과 속도 제어 가능

Model	Type	Capacity (kg)	Chain Falls	Speed (m/min)	
				Up	Down
H2-100SPB	Standard	1000	1	6.5	8

Lift (m)	Air Pressure (kg/cm ²)	Air Consumption (m ³ /min)	Air Inlet	Mass (kg)
3	6	1.6	1/2"	40

